

Unified railcar coaches



OPERATING MANUAL

Table of Contents

1. Generalities	2
2. Couplings and accessories.....	3
A. Accessories bag	3
B. Coupler assembly	4
3. Body disassembly	6
4. Electronics.....	7
5. Spare Parts	8

1. Generalities

A REE product is a finely detailed product with numerous features. Therefore, it is important to follow some guidelines regarding the use of your model.

Remove the coach from its foam housing using the plastic protective sheet. This allows you to handle the model without the risk of breaking it. Then, carefully take the railcar and position it on the track. Using a track laying ramp can be helpful.

Your model is ready to run.

This model has been designed to operate on a minimum radius of 360mm.

The entire REE Models team wishes you many enjoyable gaming sessions with your model.

WARRANTY

Your model is covered by a two years parts and work warranty. This warranty will apply when presenting a purchase receipt with the date of purchase.

2. Couplers and accessories

The model is delivered with one end equipped with detailed buffer beams, and the other end with a NEM socket featuring a standard coupler.

A. Accessories bag

In the accessories bag delivered with the model, you will find:

- All the necessary parts to equip the second end with a functional coupler,
- Complete detailing parts for one end.

Red and cream versions:

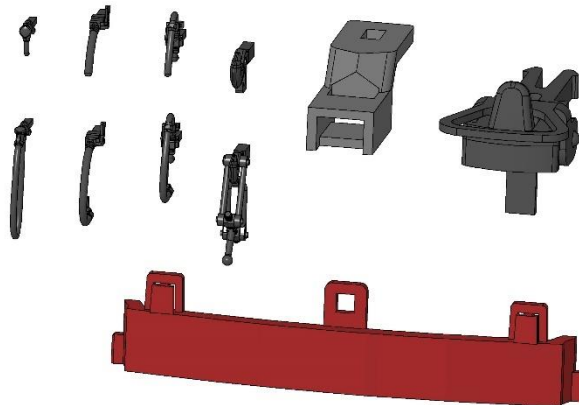

Blue versions:

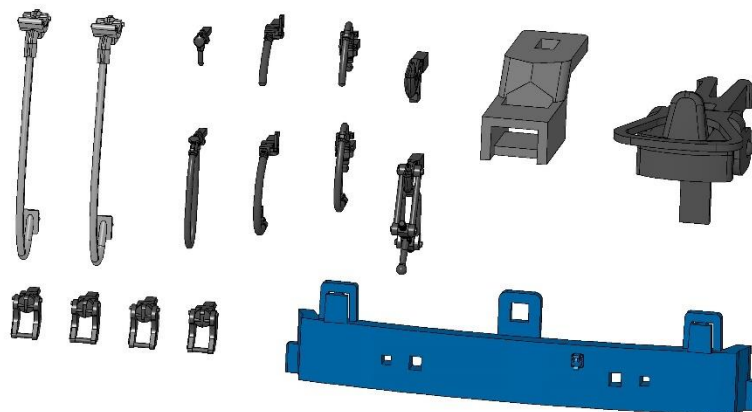

If you wish to equip your coach with a different coupling head, you can use any model following the NEM 360 standard.

B. Coupler assembly

To fit a standard coupler's support:

- Start by removing the coupling, hoses, and any Khéops plugs, as indicated below depending on the versions.
Next, take off the skirts under the buffer beams; they are simply vertically plugged into the body,

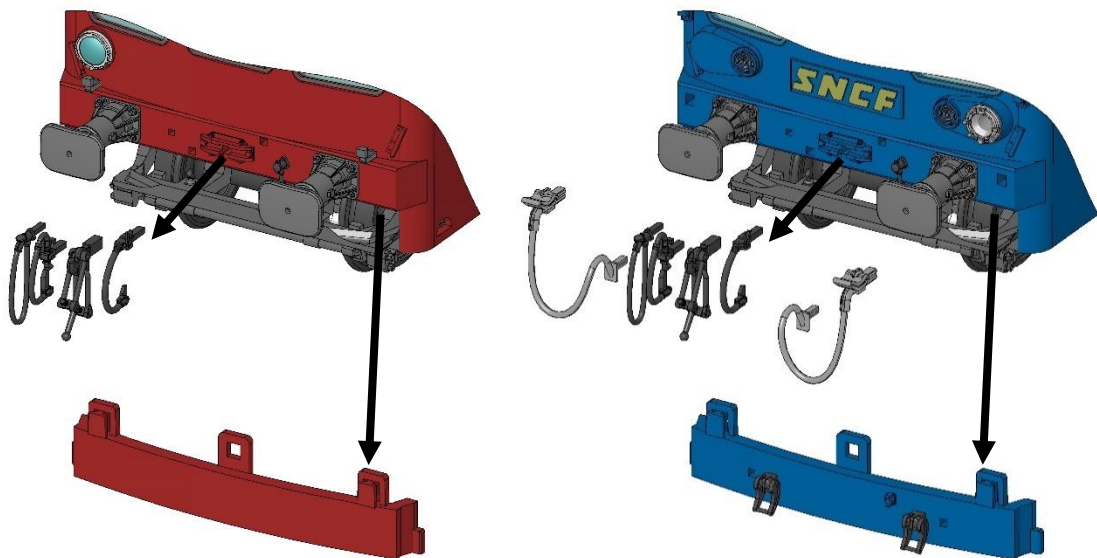

- Replace them with the shortened detailing parts:

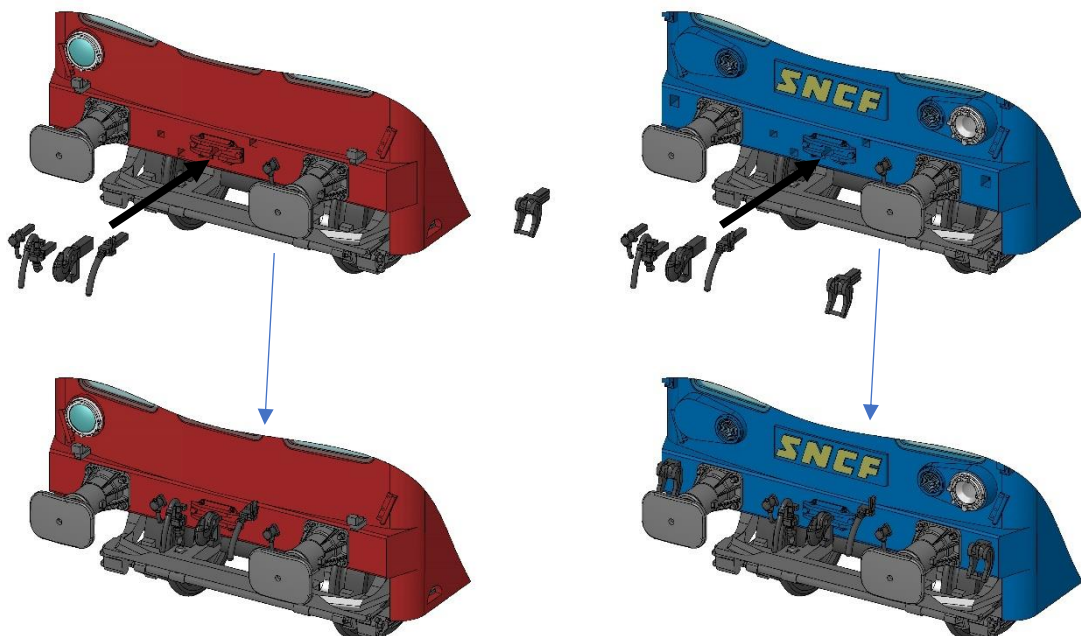

- Insert NEM support and coupler,

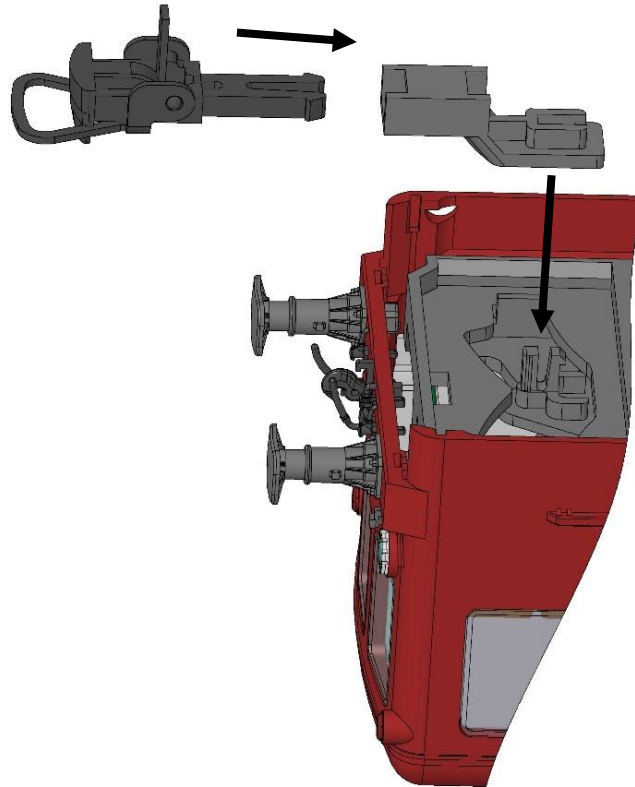

- Final look.

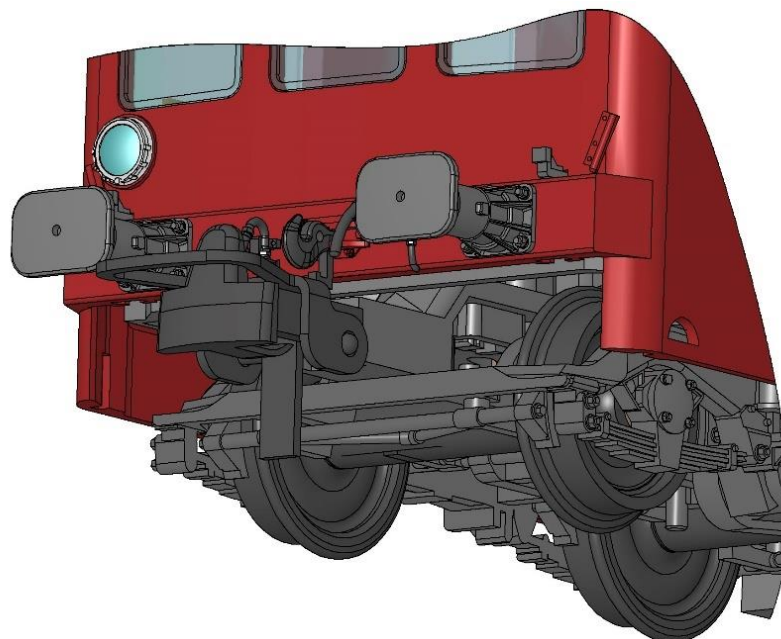

To fully detail the end delivered with a coupler, follow the same steps in reverse order.

3. Body shell disassembly

The body is held onto the chassis by a set of clips located between the passenger access doors.

Lift the body by gently pulling it apart on each side and then letting the chassis slide downwards.

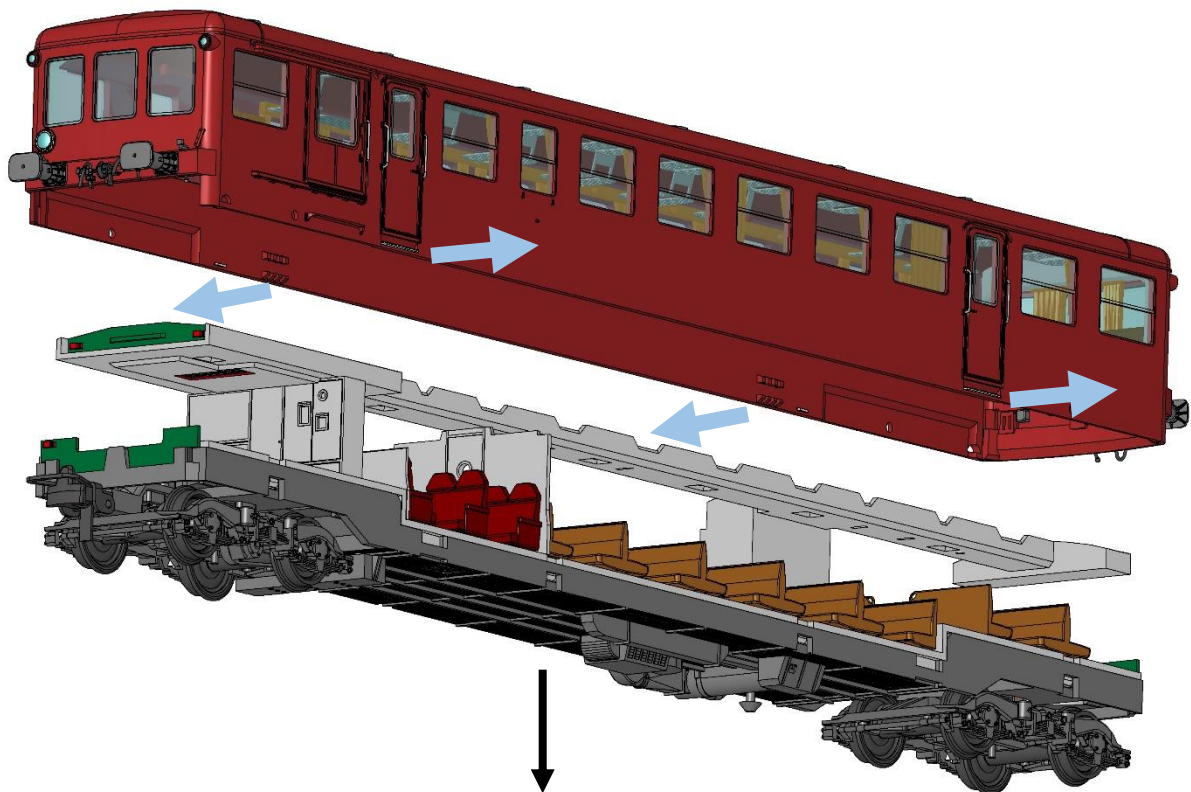

To make this operation easier, there is no electric connection between body and frame.

Careful: During reassembly, you must insert the chassis into the body diagonally on the passenger compartment side (opposite the luggage compartment) to position the ceiling above the large bench fixed to the body.

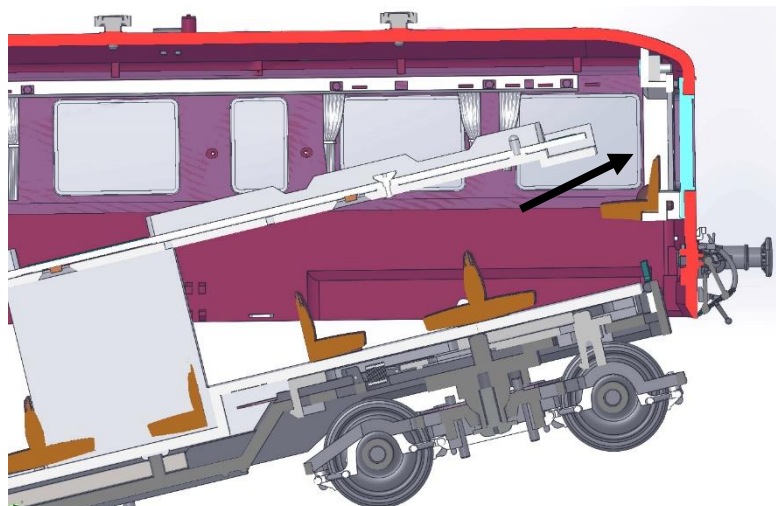

4. Electronics.

The coach operates native with its interior lighting and red lights at one end in both analog and digital modes. It uses a simple and reliable electronic board to meet the needs of most customers.

It works seamlessly in both analog and digital modes.

In both analog and digital mode, the interior lighting and red lights at one end operate simultaneously.

For digital enthusiasts who wish to control a maximum number of functions, we offer a complete technical solution with a decoder as spare part to control all lighting features:

- Interior lighting,
- Reversed red lights based on running direction,
- Reversed white lights (on equipped models),
- Reversed top lights (on equipped models).

This complete kit will easily fit into the model, replacing the original electronic board. The replacement process takes only a few minutes and requires no soldering.

The digital DCC electronic board will be sold under the reference number:

XB-PCB-XR-02

5. Spare Parts

In case of any need, REE company has a stock of spare parts.

In the following pages, you will find images, designations, and references for each part of the model.

BEWARE!

For any spare part order, you have to precise:

1/ The part's reference given in the following charts











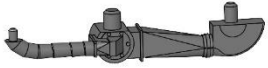

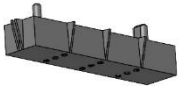
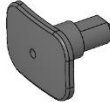

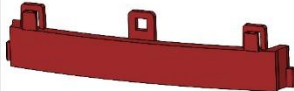
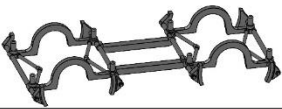

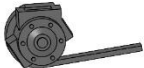

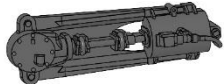

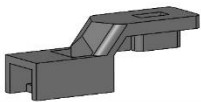

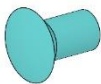

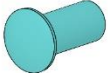
**2/ The reference of your model box
(on the sticker: "MB-055" for example)**

AND

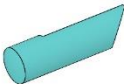
Your NAME, SURNAME and POSTAL ADDRESS

Note: In the following charts, the CAD parts colours can be different from your model. This is why it is important to specify the reference of your railcar.

PARTS REFERENCES

	B-01730-00 GROUPE VENTILATEUR XR UNIFIEE		B-60367-00 ENTOURAGE PHARE MOD XR UNIFIEE
	B-01731-01 COFFRE BATTERIES XR UNIFIEE		B-60377-00 PLATEAU TAMPON ETROIT
	B-01732-01 BRIDE TIMON XR UNIFIEE		B-60381-00 JUPE XR UNIFIEE ORIGINE
	B-03107-02 FREINS BOGIE DECAUVILLE		B-60382-00 JUPE XR UNIFIEE MOD
	B-03108-01 DYNAMO ORIGINE		B-62020-00 CONDUITE PRINCIPALE RGP1 COUPE
	B-03110-01 DYNAMO MOD		B-62021-00 CONDUITE GENERALE
	B-09119-00 BOITIER NEM XR UNIFIEE		B-62036-00 PRISE AVANT FERMEE
	B-13066-00 CONDUIT PHARES ANCIEN XR UNIFIEE		B-62071-00 AERATEUR DOME
	B-13067-00 CONDUIT PHARES MOD XR UNIFIEE		B-62072-00 AERATEUR CYLINDRE
	B-13068-00 CONDUIT PHARES ROUGES XR UNIFIEE		B-62075-00 AERATEUR WC
	B-13069-00 CONDUIT FANAL XR UNIFIEE		B-62098-00 RAMBARDE XR UNIFIEE
	B-13070-00 DIFFUSEUR FANAU XR UNIFIEE		B-62099-00 RAMBARDE FOURGON XR UNIFIEE
	B-60366-00 ENTOURAGE PHARE ANCIEN XR UNIFIEE		B-62100-00 CONDUITE FREIN XR UNIFIEE

	B-62101-00 CONDUITE FREIN XR UNIFIEE COUPE		V018-SE42AC SKI REMORQUE
	B-62102-00 MARCHEPIED XR UNIFIEE		
	B-62103-00 PORTE LANTERNE XR UNIFIEE		
	B-62104-00 PRISE KEOPS XR UNIFIEE		
	V018-SE01 BOGIE DECAUVILLE		
	V018-SE01AC_SKI BOGIE DECAUVILLE		
	V018-SE02 BOGIE DECAUVILLE DYNAMO ORI		
	V018-SE02AC BOGIE DECAUVILLE DYNAMO ORI		
	V018-SE04 BOGIE DECAUVILLE DYNAMO MOD		
	V018-SE04AC BOGIE DECAUVILLE DYNAMO MOD		
	V018-SE08 ESSIEU DECAUVILLE		
	V018-SE08AC ESSIEU DECAUVILLE		
	V018-SE30 TAMPONS XR_UNIFIEES		
	V018-SE31 ACCESSOIRES XR_UNIFIEES		
	V018-SE32 ACCESSOIRES XR_UNIFIEES MOD		



**REE-MODELES - Sales Department
After-Sales-Service**

46 ROUTE DE PARIS - 77370 - NANGIS

Tel : +33(0)1.64.00.31.20

Email : info@ree-modeles.com

After-Sales-Service :

Direct line : +33(0)1.60.58.60.60

Email : sav@ree-modeles.com

Web : www.ree-modeles.com